

NS060

Light Sensor

V1.1.0



Specifications

Change History

Document Version	Release Date	Description
V1.1.0	2020-05-22	Updated the cable length description.

Introduction

The NS060 is a light sensor designed and produced by NovaStar. It can be connected to NovaStar sending cards, asynchronous cards or multifunction cards for ambient brightness monitoring, allowing for automatic brightness adjustment of LED display.

The sensor body of NS060 is made of aluminum alloy. The sensor surface adopts micro-arc oxidation process, and therefore it is highly UV-resistant and will not be discolored. The joint between the sensor body and male connector has a very-deep groove and is extremely waterproof.

Features

- Ambient brightness monitoring, allowing for automatic brightness adjustment of LED display
- Capable of connecting to sending cards (MSD300, MSD600, MCTRL300, etc.), asynchronous cards or multifunction cards
- A 5-meter cable provided (NS060-5A model), extendable to 10 meters (NS060-10A model)
- Mildew, moisture and salt-mist resistant design, ideal for outdoor applications
- No external power supply required

Applications

The NS060 light sensor can work with devices that have light sensor connectors, such as sending cards, asynchronous cards and multifunction cards. It must be placed in the same environment with the LED display.

The connection between the light sensor and multifunction card is shown in [Figure 1](#).

Figure 1 Connection between NS060 and MFN300 multifunction card

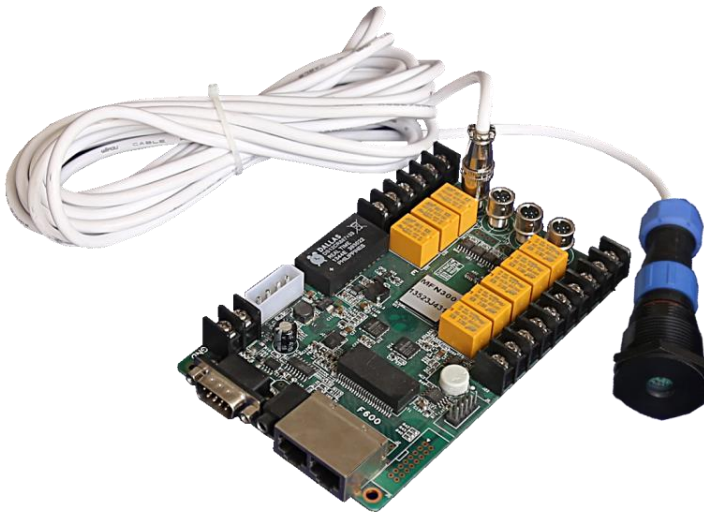

Dimensions

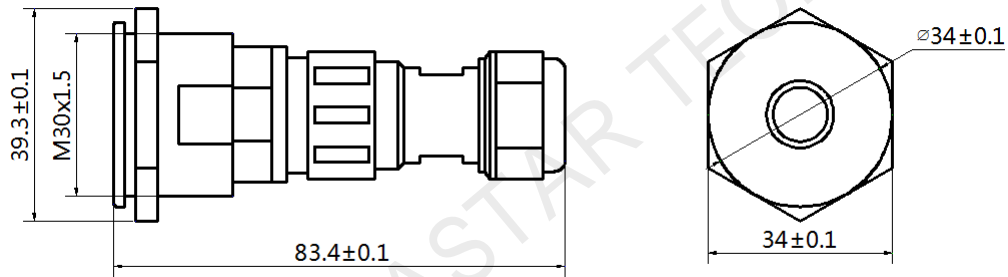

Unit: mm

Assembly

Preparation

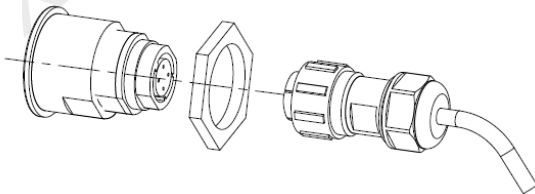

Assembly

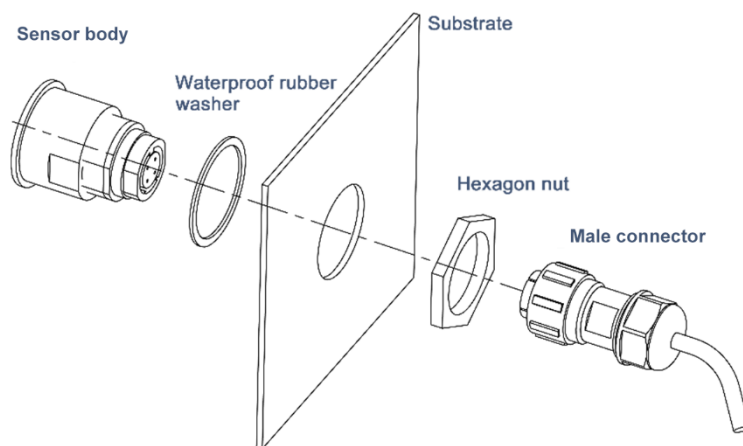

Complete

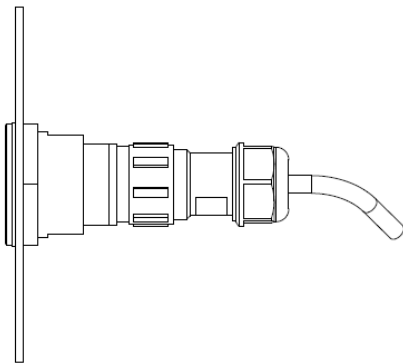

Tips: It is recommended that you apply outdoor waterproof adhesive to the joint between the sensor body and substrate after assembly, and check the joint regularly.

Specifications

Item	Specifications
Rated voltage	5 V DC
Operating temperature	-20°C to +70°C
Operating humidity	0% RH to 99% RH, non-condensing
Brightness measurement range	0 lux to 65535 lux
Cable length	5 m (NS060-5A model) 10 m (NS060-10A model)

Copyright © 2020 Xi'an NovaStar Tech Co., Ltd. All Rights Reserved.

No part of this document may be copied, reproduced, extracted or transmitted in any form or by any means without the prior written consent of Xi'an NovaStar Tech Co., Ltd.

Trademark

NOVA STAR is a trademark of Xi'an NovaStar Tech Co., Ltd.

Statement

You are welcome to use the product of Xi'an NovaStar Tech Co., Ltd. (hereinafter referred to as NovaStar). This document is intended to help you understand and use the product. For accuracy and reliability, NovaStar may make improvements and/or changes to this document at any time and without notice. If you experience any problems in use or have any suggestions, please contact us via contact info given in document. We will do our best to solve any issues, as well as evaluate and implement any suggestions.

[Official website](http://www.novastar.tech)
www.novastar.tech

[Technical support](mailto:support@novastar.tech)
support@novastar.tech