



Specifications

Receiving Card MRV410

Product images provided in this file are for reference only, and the actual products shall prevail.

Rev1.1.3 NS110100255

Overview

MRV410 is the EMC version of MRV210 with its effective reduction of the electromagnetic radiation of the whole system.

Features

- 1) Single card outputs 16-group of RGBR 'data;
- 2) Single card outputs 20-group of RGB data;
- 3) Single card outputs 24-group of RGB data;
- 4) Single card outputs 64-group of serial data ;
- 5) Single card supports resolution of 256x226;
- 6) Configuration file read back;
- 7) Temperature monitoring;
- 8) Ethernet cable communication status detection;
- 9) Power supply voltage detection;
- 10) Pixel-by-pixel brightness and chromaticity calibration Brightness and chromaticity calibration coefficients for each LED;
- 11) Each of the ports has VCC PIN and the module can provide power supply to the control system;
- 12) Comply with EU CE-EMC CLass B standard.

Output interface definition

Under all the four different working modes of it, four 26P interfaces can output different data; interface is defined as follows:

1) 16-group data mode (With virtual output)

Supporting 16-group of RGBR 'parallel data, defined as follows:

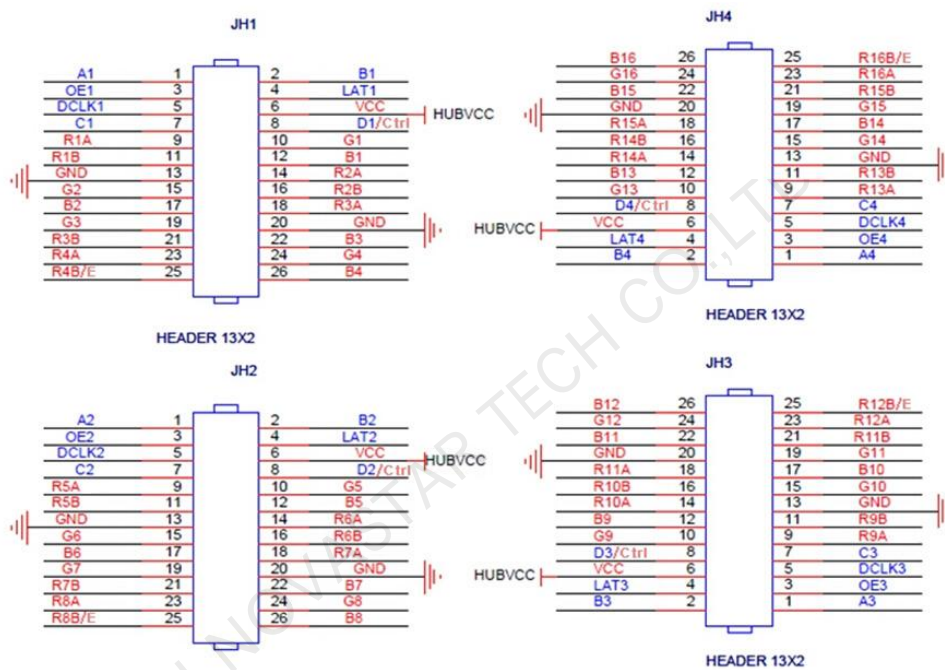

It support 1/32 scan mode in 16-group data mode, and R4B ,R8B ,R12B ,R16B are decoding signal E.

Pin 9 is decoding signal Ctrl below 1/16 scan mode(contain 1/16 scan). Pin 8 is decoding Ctrl signal in 1/8 scan and below.

JH1				JH2			
1	A1	B4	2	1	A2	B2	2
3	OE1	LAT1	4	3	OE2	LAT2	4
5	DCLK1	VCC	6	5	DCLK2	VCC	6
7	C1	D1	8	7	C2	D2	8
9	R1A	G1	10	9	R5A	G5	10
11	R1B	B1	12	11	R5B	B5	12
13	GND	R2A	14	13	GND	R6A	14
15	G2	R2B	16	15	G6	R6B	16
17	B2	R3A	18	17	B6	R7A	18
19	G3	GND	20	19	G7	GND	20
21	R3B	B3	22	21	R7B	B7	22

23	R4A	G4	24	23	R8A	G8	24
25	R4B	B4	26	25	R8B	B8	26

JH3				JH4			
1	A3	B3	2	1	A4	B4	2
3	OE3	LAT3	4	3	OE4	LAT4	4
5	DCLK3	VCC	6	5	DCLK4	VCC	6
7	C3	D3	8	7	C4	D4	8
9	R9A	G9	10	9	R13A	G13	10
11	R9B	B9	12	11	R13B	B13	12
13	GND	R10A	14	13	GND	R14A	14
15	G10	R10B	16	15	G14	R14B	16
17	B10	R11A	18	17	B14	R15A	18
19	G11	GND	20	19	G15	GND	20
21	R11B	B11	22	21	R15B	B15	22
23	R11A	G12	24	23	R16A	G16	24
25	R12B	B12	26	25	R16B	B16	26

2) 20-group data mode

Supporting 20 sets of parallel data, defined as follows:

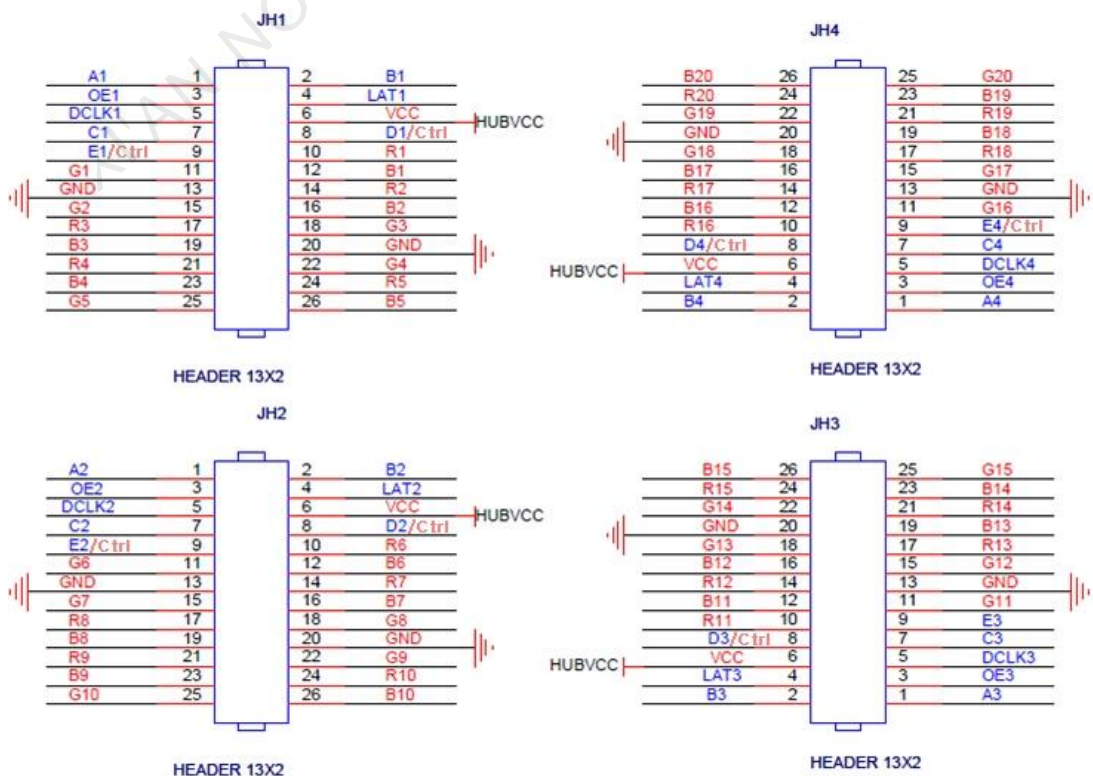

Pin9 is Ctrl signal in 1/16 scan and below, and Pin 8 is decoding Ctrl signal in 1/8 scan and below.

JH1				JH2			
1	A1	B1	2	1	A2	B2	2
3	OE1	LAT1	4	3	OE2	LAT2	4
5	DCLK1	VCC	6	5	DCLK2	VCC	6
7	C1	D1	8	7	C2	D2	8
9	E1	R1	10	9	E2	R6	10
11	G1	B1	12	11	G6	B6	12
13	GND	R2	14	13	GND	R7	14
15	G2	B2	16	15	G7	B7	16
17	R3	G3	18	17	R8	G8	18
19	B3	GND	20	19	B8	GND	20
21	R4	G4	22	21	R9	G9	22
23	B4	R5	24	23	B9	R10	24
25	G5	B5	26	25	G10	B10	26

JH3				JH4			
1	A3	B3	2	1	A4	B4	2
3	OE3	LAT3	4	3	OE4	LAT4	4
5	DCLK3	VCC	6	5	DCLK4	VCC	6
7	C3	D3	8	7	C4	D4	8
9	E3	R11	10	9	E4	R16	10
11	G11	B11	12	11	G16	B16	12
13	GND	R12	14	13	GND	R17	14
15	G12	B12	16	15	G17	B17	16
17	R13	G13	18	17	R18	G18	18
19	B13	GND	20	19	B18	GND	20
21	R14	G14	22	21	R19	G19	22
23	B14	R15	24	23	B19	R20	24
25	G15	B15	26	25	G20	B20	26

3) 24-group data mode

Supporting 24 sets of parallel data, Serial data decoding is required for scan mode above 1/4 scan (Serial data decoding circuit in the appendix), defined as follows:

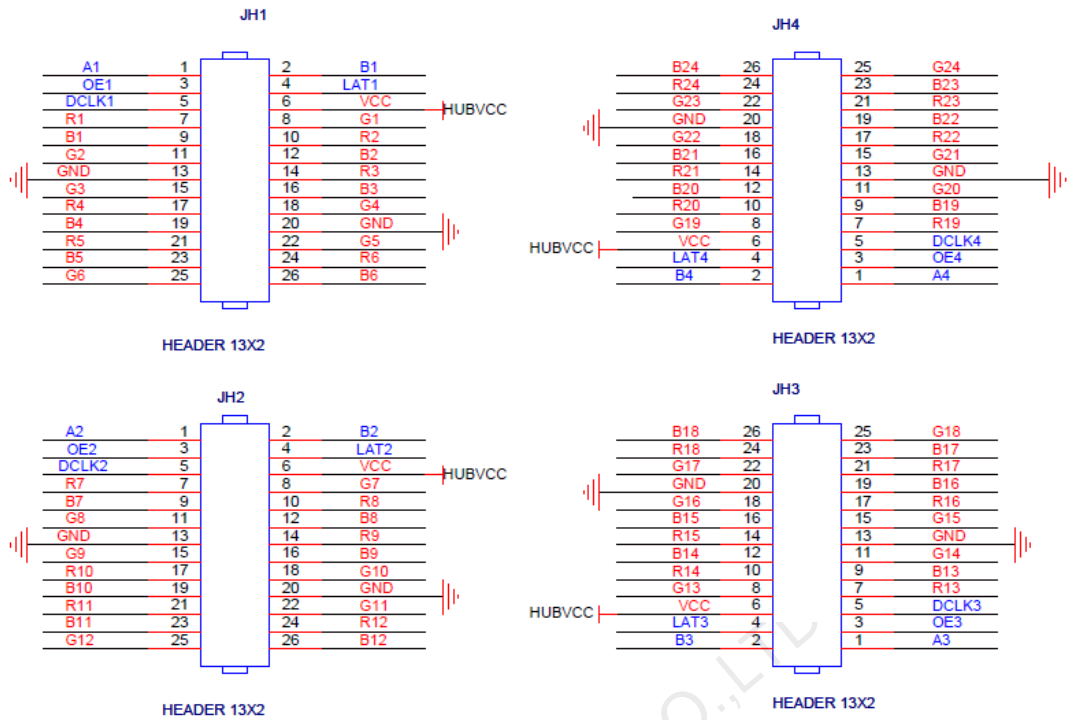

JH1				JH2			
1	A1	B1	2	1	A2	B2	2
3	OE1	LAT1	4	3	OE2	LAT2	4
5	DCLK1	VCC	6	5	DCLK2	VCC	6
7	R1	G1	8	7	R7	G7	8
9	B1	R2	10	9	B7	R8	10
11	G2	B2	12	11	G8	B8	12
13	GND	R3	14	13	GND	R9	14
15	G3	B3	16	15	G9	B9	16
17	R4	G4	18	17	R10	G10	18
19	B4	GND	20	19	B10	GND	20
21	R5	G5	22	21	R11	G11	22
23	B5	R6	24	23	B11	R12	24
25	G6	B6	26	25	G12	B12	26

JH3				JH4			
1	A3	B3	2	1	A4	B4	2
3	OE3	LAT3	4	3	OE4	LAT4	4
5	DCLK3	VCC	6	5	DCLK4	VCC	6
7	R13	G13	8	7	R19	G19	8
9	B13	R14	10	9	B19	R20	10
11	G14	B14	12	11	G20	B20	12
13	GND	R15	14	13	GND	R21	14

15	G15	B15	16	15	G21	B21	16
17	R16	G16	18	17	R22	G22	18
19	B16	GND	20	19	B22	GND	20
21	R17	G17	22	21	R23	G23	22
23	B17	R18	24	23	B23	R24	24
25	G18	B18	26	25	G24	B24	26

4) 64-group serial data mode

Supporting 64 sets of serial data, defined as follows:

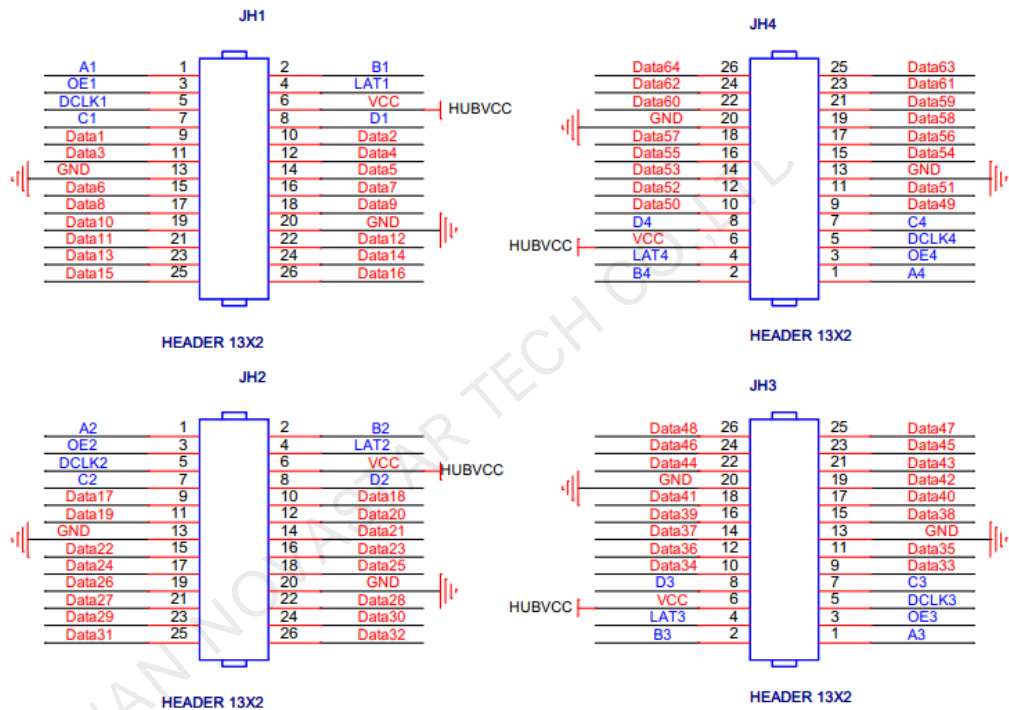

Under serial mode, there are 64 data cables totally. Each cable can drive one LED bar independently.

In case of horizontal LED bar, the default is that Data1 drives the first row from the top, and Data64 drives the 64th row.

In case of vertical LED bar, the default is that Data1 drives the first column of from the left, and Data64 drives the 64th column.

JH1				JH2			
1	A1	B1	2	1	A2	B2	2
3	OE1	LAT1	4	3	OE2	LAT2	4
5	DCLK1	VCC	6	5	DCLK2	VCC	6
7	C1	D1	8	7	C2	D2	8
9	Data1	Data2	10	9	Data17	Data18	10
11	Data3	Data4	12	11	Data19	Data20	12
13	GND	Data5	14	13	GND	Data21	14
15	Data6	Data7	16	15	Data22	Data23	16
17	Data8	Data9	18	17	Data24	Data25	18
19	Data10	GND	20	19	Data26	GND	20
21	Data11	Data12	22	21	Data27	Data28	22
23	Data13	Data14	24	23	Data29	Data30	24
25	Data15	Data16	26	25	Data31	Data32	26

JH3				JH4			
1	A3	B3	2	1	A4	B4	2
3	OE3	LAT3	4	3	OE4	LAT4	4
5	DCLK3	VCC	6	5	DCLK4	VCC	6
7	C3	D3	8	7	C4	D4	8
9	Data33	Data34	10	9	Data49	Data50	10
11	Data35	Data36	12	11	Data51	Data52	12
13	GND	Data37	14	13	GND	Data53	14
15	Data38	Data39	16	15	Data54	Data55	16
17	Data40	Data41	18	17	Data56	Data57	18
19	Data42	GND	20	19	Data58	GND	20
21	Data43	Data44	22	21	Data59	Data60	22
23	Data45	Data46	24	23	Data61	Data62	24
25	Data47	Data48	26	25	Data63	Data64	26

Dimensions

Thickness of the board is about 2mm. The overall thickness (board thickness + thickness of the components on front and back side) is about 18mm.

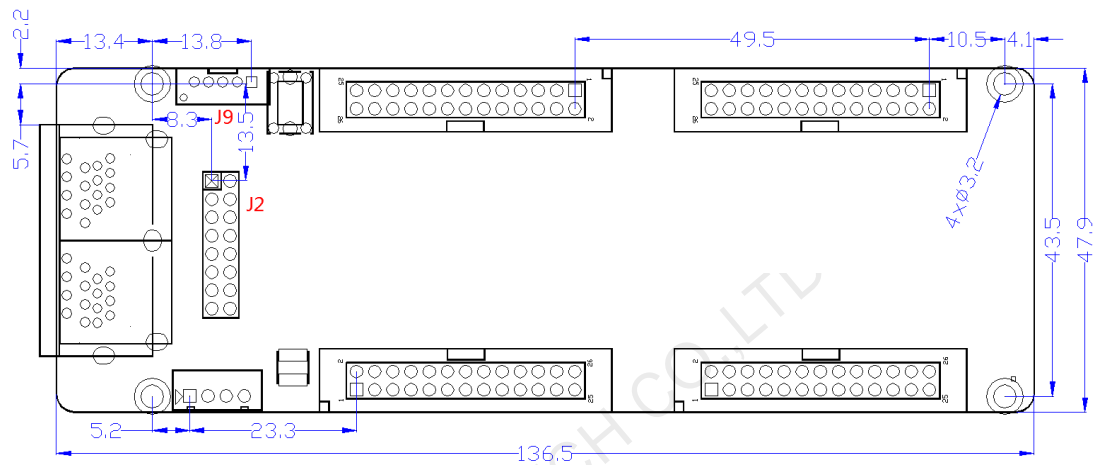

Unit: mm.

Appearance

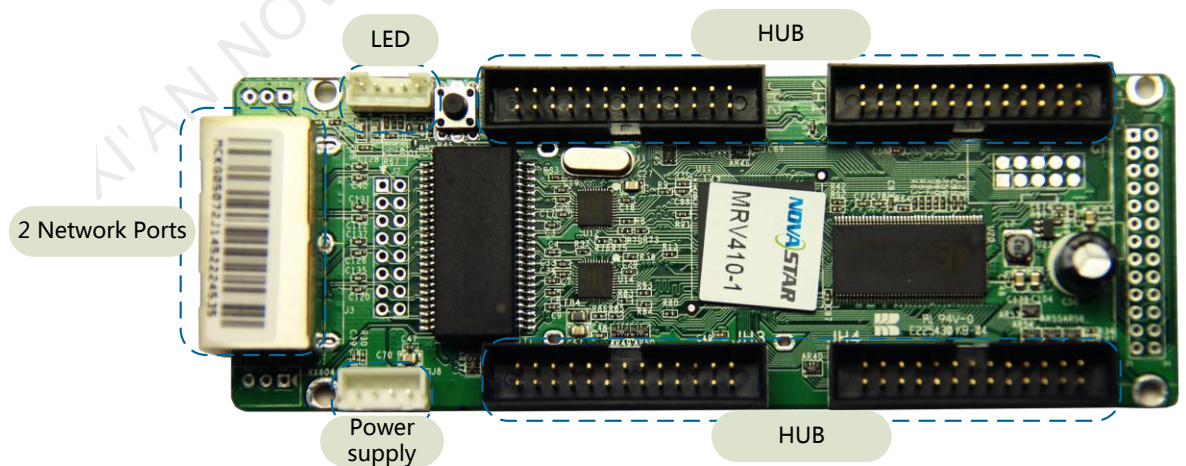

Note: Product images provided in this file are for reference only, and the actual products shall prevail.

J9 definition (Indicator Light Socket)

1	2	3	4	5
STA_LED	LED +/3.3V	PWR_LED -	KEY +	KEY -/GND

Specifications

	MIN	TYP	MAX	UNIT
Rated voltage	3.3	5.0	5.5	V
Rated current	0.33	0.50	0.55	A
Temperature of working environment	-20.0~70.0			°C
Humidity of working environment	10.0~90.0			%

Specific Model List

To meet the needs of different customers, Nova has provided more specific models of the products, including standard products in stock.

Other models need to be customized.

Model	Specification
MRV410 - 1	Standard model, male connector on top
MRV410 - 2	Male connector on bottom
MRV410 - 3	Female connector on top
MRV410 - 4	Female connector on bottom

Appendix

Serial data decoding circuit :

